

# Swing Gate Opener Manual

## Warnings

**Please read this instruction manual carefully before the installation of gate operator system.**

**A wired photo eye sensor must be installed for this gate operator to function properly (UL325-2016)**

**This manual is exclusively for qualified installation personnel. We are not responsible for improper installation and failure to comply with local electrical and building regulations.**

**\* Be aware of the hazards that may exist in the procedures of installation and operation of the gate-automated system. Besides, the installation must be carried out in conformity with local standards and regulations.**

**\* If the system is correctly installed and used following all the standards and regulations, it will ensure a high degree of safety.**

**\* Make sure that the gates work properly before installing the gate-automated system and confirm the gates are appropriate for the application.**

**\* Do not let children operate or play with the gate-automated system.**

**\* Do not cross the path of the gate-automated system when operating**

**\* Please keep all the control devices and any other pulse generator away from children to avoid the gate-automated system being activated accidentally.**

- \* **Do not make any modifications to any components that is not in this manual.**
- \* **Do not try to manually open or close the gate before you release the gear motor.**
- \* **If there is a failure that cannot be solved and is not mentioned in this manual, please contact qualified installation personnel.**
- \* **Do not use the gate-automated system before all the procedures and instructions have been carried out and thoroughly read.**
- \* **Test the gate-automated system weekly and have qualified installation personnel to check and maintain the system at least every 6 months.**
- \* **Install warning signs on the both sides of the gate to warn the people in the area of potential hazards.**

#### **Technical Characteristics**

Motor: 24VDC motor with mechanical release

Gear type: Worm gear

Max absorbed power: 144W

Peak thrust: 3500N

Nominal thrust: 3000N

Stroke length: 300mm

Power supply: 110VAC converted to 24VDC with built in transformer

Nominal input power: 2A

Maximum operating current: 5.5A for maximum 10 seconds

Maximum gate weight: 500 kg for dual leaf

## **Product Description and Applications**

### **Applications**

This model is for residential or light commercial automation of a single or dual leaf gate. Power is 110vac. In case of power failure, the operators can be released by special keys to move the gate manually. (battery backup not included and must be purchased separately)

### Description of the Automation

The following diagram of typical installation describes some terms and accessories of a gate automation system.

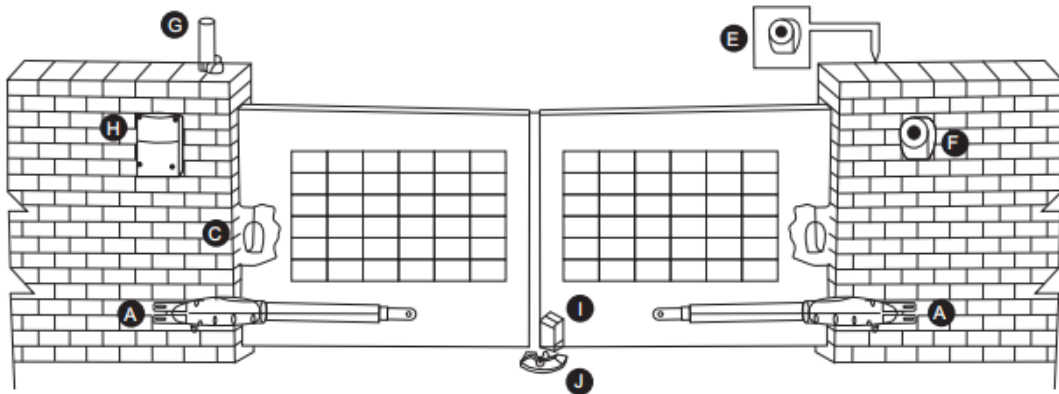

### Motors, Components Illustration

The installation procedure may differ due to various accessories and quantities installed. The basic wiring diagram is shown in below photo. Gate operators, photo eye, control box, keypad, warning light. Access controls are not included and must be purchased separately.

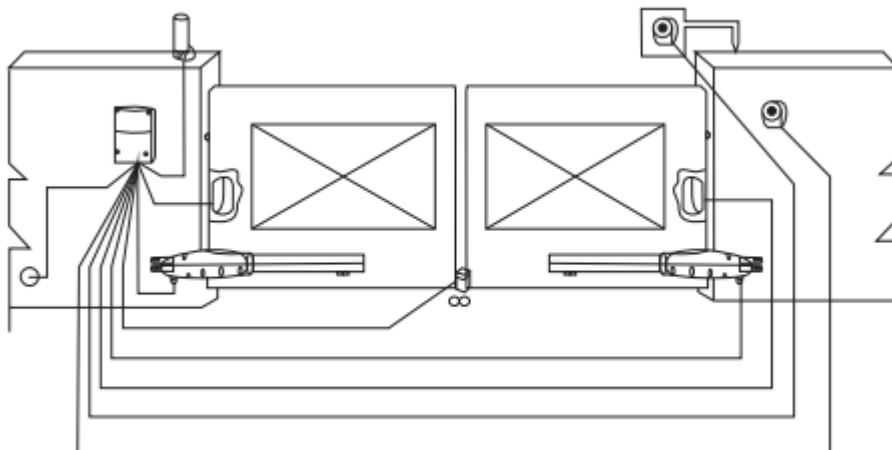

### **Power connection**

The installation of 110vac power supply cable to the Control Box should be done by a qualified professional electrician. **All high voltage wiring must be in conduit.**

It is highly recommended to ground the system. Please make sure to shut off the power before installation or maintenance.

### **Installation**

Check the following items before doing the installation:

Make sure the weight and dimension of the gate conform to the operation range of the gate motor. Don't use the gate motor if the gate specifications do not meet the requirements.

Make sure the gate structure conforms to the criteria of automatic operation and force regulations.

Make sure there is no serious friction existing in the opening or closing travel of the gate leaves.

Make sure the gate is at horizontal level that the gate will not move aside at any position.

Make sure the gate can bear the impact of the motor torque when it is installed on any hole of the bracket which the surface is sufficiently sturdy.

Make sure the photo eye sensors are installed on flat surfaces to ensure the two ends of receiving and transmitting corresponded to each other.

Check the dimensions of the motors as below: (25 mm = 1 inch)

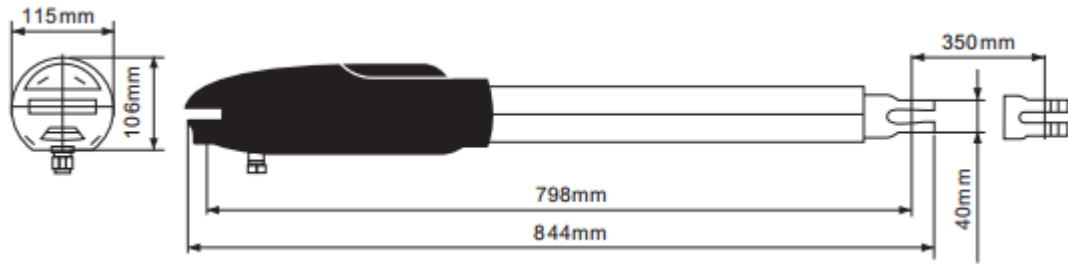

Make sure to leave enough space when the gate is opening.

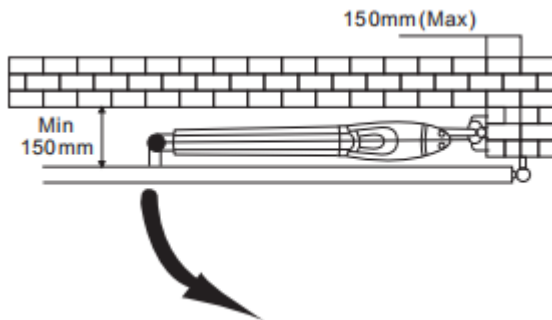

**If the gate is OPENED OUTWARD, please leave at least 70 mm (3 inches) between the post brackets and the gate.**

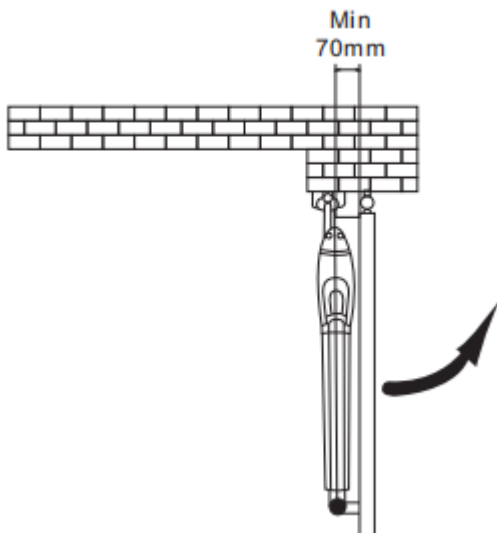

Using the leaf-opening angle as criteria to make sure all criteria in Figure 17 can be met

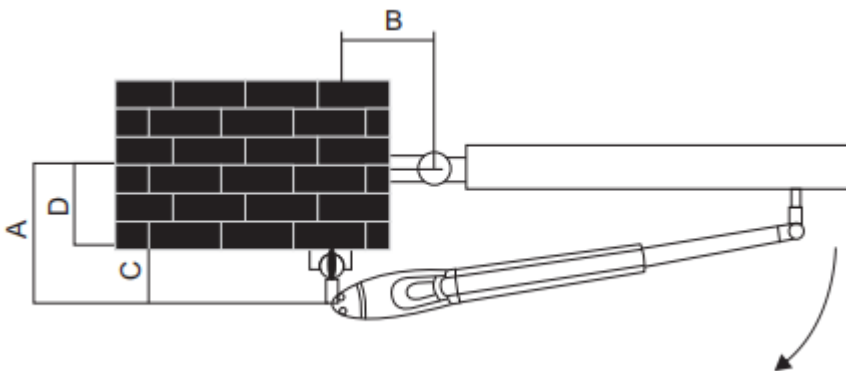

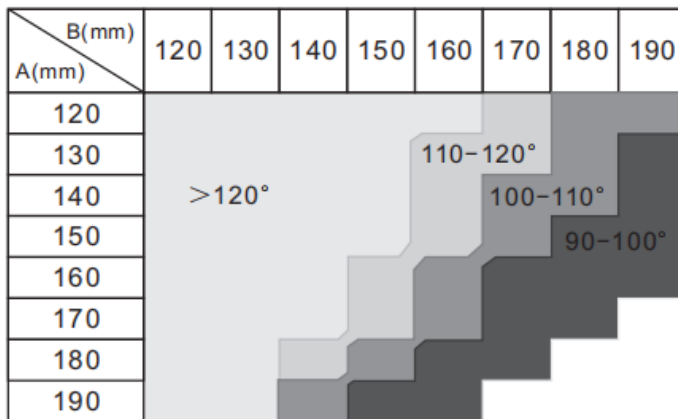

**FIGURE 17**

“C” value is 139mm (5-1/2”)

“D” can be measured from the gate easily

“A” = “C” + “D”

The value of “B” can be calculated from the value of “A” and the leaves opening angle. Example: If “A” =160mm (6-1/4”) with the leaves opening angle of 100 degrees, then the value of “B” is approximate 190mm (7-1/2”)

NOTE: Please make sure “B” and “A” are similar or the same in value that the leaves can be operated smoothly to reduce the burden of the motor.

NOTE: A 120-degree opening may be obtained but 110 degrees is the recommended limit.

## **Installation of the Gear Motors**

### **1. Mount Post Bracket**

Choose the desired dimensions of the motors and position to be installed.

Be sure mounting surface the brackets will be installed on is smooth, vertical and rigid.

Arrange the cable conduit for power supply cable of the motors.

Loosen the two screws and remove the back cover of the motor as shown in photo

Place the gate leaves in the **closed position**.

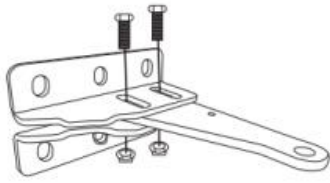

**Figure 18**

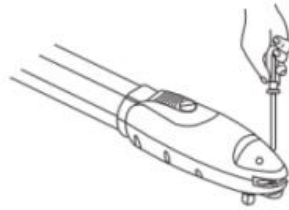

**Figure 19**

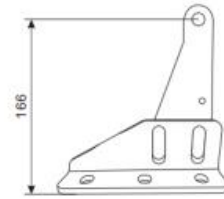
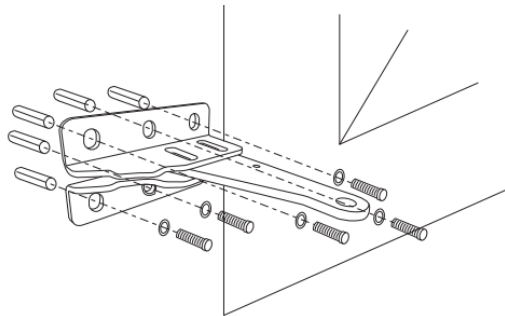

**Figure 20**

Refer to the “B” dimension in figure 17, place the post bracket plate in the correct position on the mounting surface.

Place the post bracket on the surface to be installed and mark the drilling points then drill 3/8 holes x four through the hinge post and fasten the brackets with nuts and washers. The drawing below shows tech screws but it is highly recommended to drill all the way through the hinge post and to use bolts long enough to bolt on the back side.

Make sure the bracket is level. There are two pieces to the bracket. You have already fastened the post bracket to the post, now bolt the top part of the bracket to the one that has been mounted. Finger tighten the bolts only for now - the bracket will find its own spot as you swing the gate open from the **closed position**.



**Figure 21**

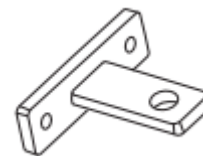
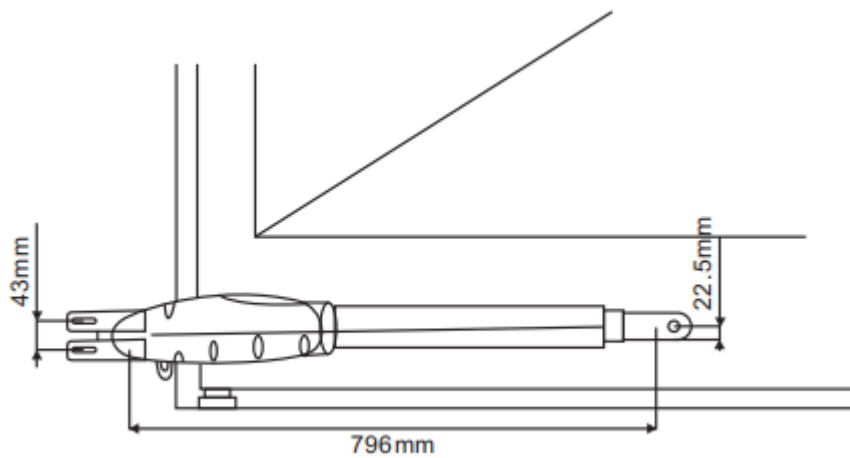

**Figure 22**

Refer to Figure 23, the distance between gate attach bracket mounting hole of the motor and post



bracket mounting hole is 796mm (31") the gate attach



**Figure 23**

Now the post bracket is securely fastened to the hinge post. Next, with the gate in the **closed position** clamp and fix the motor front bracket on the gate temporarily.

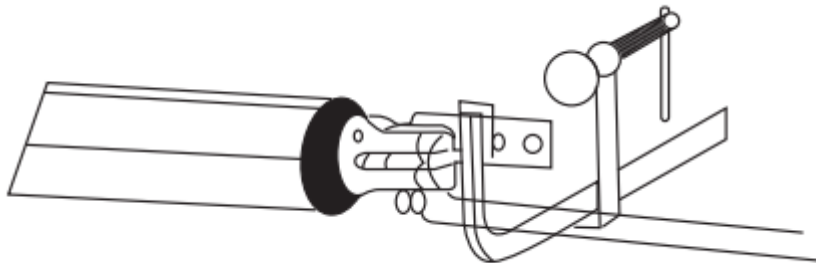

**Figure 24**

Fasten the gate attach bracket nut tightly and then loosen it 1/2 turn so actuator can pivot.

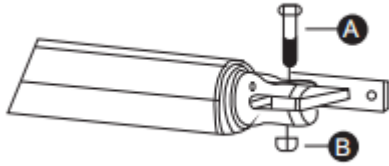

Open the gear motor cover and then take out the mounting pin as below Figure 25.

Mount the actuator to the hinge post bracket using supplied pin and insert the mounting bolt into the gate attach bracket.

This is the position of the gate in the closed position and cannot be changed once finally drilled and bolted. Be sure the actuator is level and the gate is in the desired permanent closed position.

### **Gear Motor Release**

Turn the round plate on the release part to “OPEN” position, See Figure 29

Push out the release part to the end. See Figure 30

Use the release key to turn the pin anti-clockwise to the end. See Figure 31

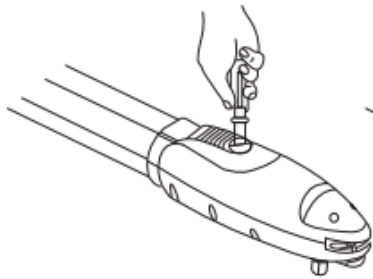

**Figure 29**

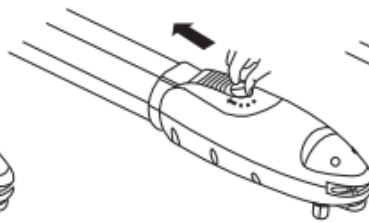

**Figure 30**

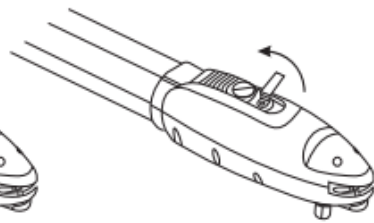

**Figure 31**

With the gear motor unlocked, slowly swing the gate open until the extension tube is fully extended. The top part of the post bracket will self-adjust to the correct position and can then be tightened securely. (remember, you had left it finger tight)

Test the bracket positions a few times and when satisfied they are in the proper position, drill and bolt the gate attach bracket permanently. There are no limits to set so at this point the actuator is ready to be powered up and used.

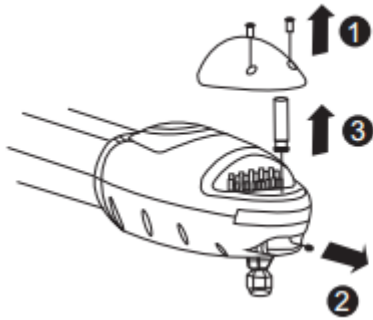

Figure 25

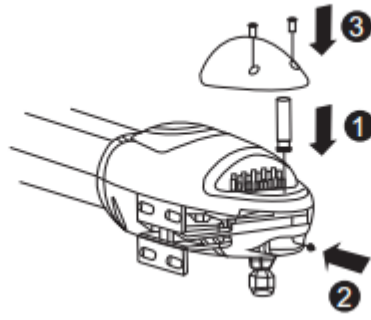

Figure 25.1

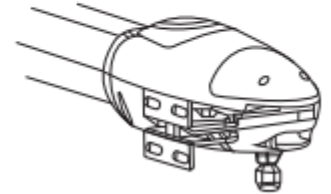

Figure 25.2

**Connect the motor power cable as shown in Figure 27**

The actuator is not pre-wired. Use 2 conductor 14-gauge stranded wire and feed it up through the strain relief nut.

Next, securely fasten to terminal blocks red to positive (white) and black to negative (yellow)

(you may use white and yellow stranded wire if available)

Close the gear motor cover by tightening the two screws as shown in Figure 28

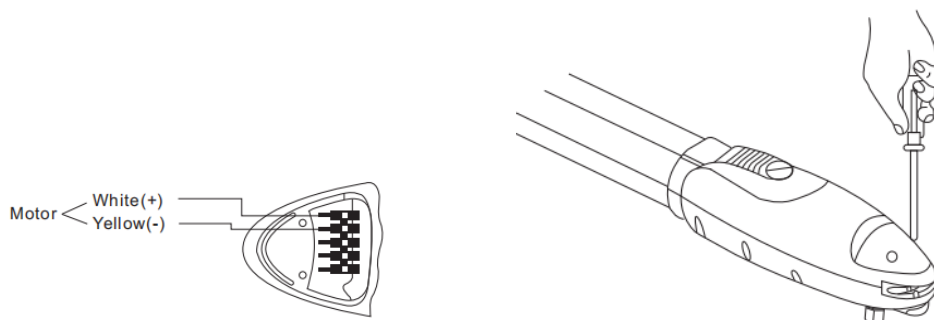

**Figure 27**

**Figure 28**

### **Mount the Control Box**

Locate a position in the most convenient spot close to the primary actuator and mount the control box using such fasteners as you see fit. Also mount a watertight junction box underneath the control box for 110vac.

### **Single gate installation -**

Run the two pair wire from the actuator to Control Box

### **Bi-parting gate installation -**

Connect a two pair wire as before to the secondary actuator and run the wire to the control box. It is recommended to use 3/4" conduit under the driveway, fashioned neatly to the control box or to a watertight junction box (and from there to the control box)

You will have to punch out the existing knockouts at the bottom of the control box for the secondary wires and any additional access controls wire. It is recommended to seal the holes with silicone caulk.

## Control board wiring diagram:

### Technical Parameters:

1. Control Panel Voltage: AC24V, available for 24VDC backup battery.
2. Suitable for single or dual swing gate opener.
3. Radio Controls: 433 MHz customized rolling code.
4. Support remote control: Can memorize 120PCS transmitters at most
5. Motor character: 24V DC motor x2

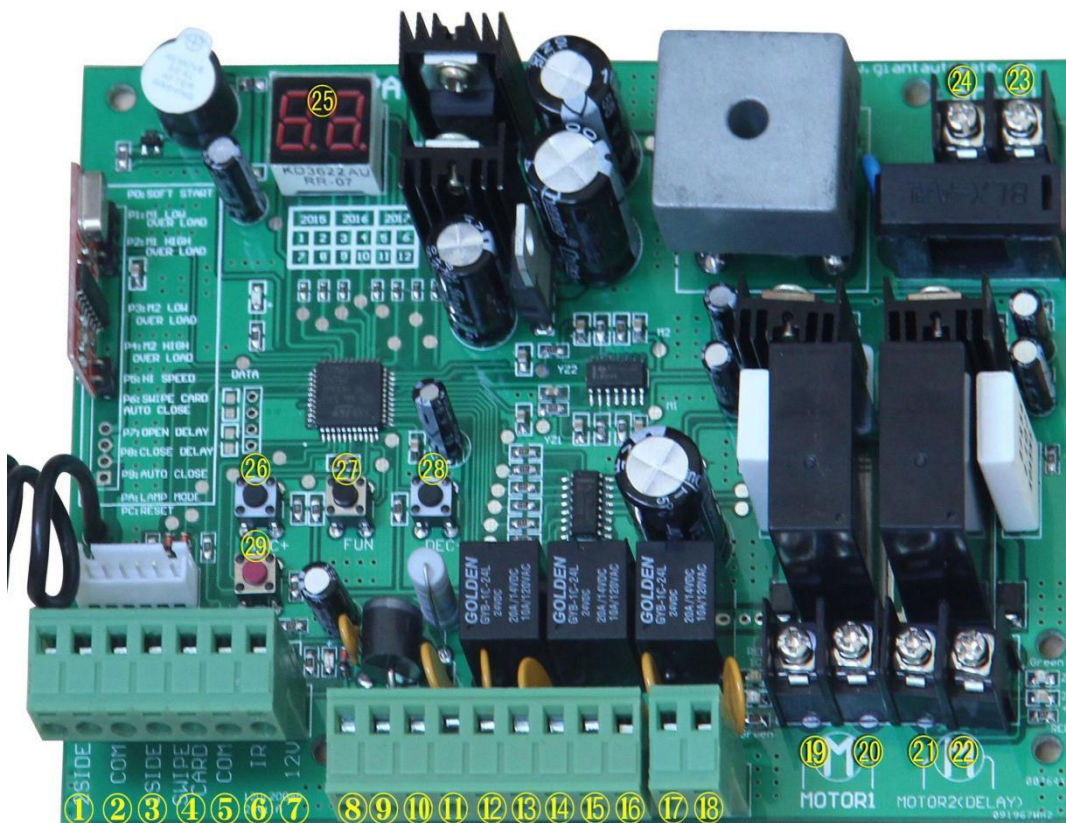

1. SIDE terminal is used for connecting any external device that operates single gate
2. COM terminal is COMMON, used for connecting the “ground” of external devices

3. 1 SIDE terminal is used for connecting any external device that operates double gate
4. Swipe Card terminal is used for connecting any external devices that will operate to open the gate such as keypad or exit sensor
5. COM terminal is COMMON, used for connecting the “ground” of external devices
6. Infrared terminal is used for connecting photo eye sensor
7. 12V DC output is used for connecting photo eye sensor (Continuous output current  $\leq 200\text{mA}$ )
8. 24V battery output is used for connecting the backup battery +
9. 24V battery output is used for connecting the backup battery -
10. 24V DC output is used for connecting external device. (such as photo eye sensor, max current output 1A)
11. GND is used for connecting the “ground” of external devices
12. 24V DC lamp output is used for connecting flashing light +
13. 24V DC lamp output is used for connecting flash light -
14. 24V DC lock output—the NF terminal which used for connecting the electromechanical lock
15. COM is COMMON, used for connecting the “ground” of lock
16. 24V DC lock output—the NA terminal which used for connecting the magnetic lock
17. 24V DC alarm output
18. 24V DC alarm output
19. Motor1 terminal is used for connecting the secondary actuator (+)
20. Motor1 terminal is used for connecting the secondary actuator (-)
21. Motor2 Delay terminal is used for connecting the primary actuator or for use with single gate positive (+)
22. Motor2 Delay terminal is used for connecting the primary actuator or for use with single gate negative (-)
23. AC24V input is used for connecting the transformer
24. AC24V input is used for connecting the transformer
25. Digital display is used for showing setting data
26. INC+ is used for figure increase when setting the data (increase)
27. FUN is used for store the data (function)

28. DEC- is used for figure decrease when setting the data (decrease)

29. Learn Button is used for program/remove remote

## **Remote control**

Button “1” depressed to operate single gate; button “2” depressed to operate double gate; button “3” depressed for alarm output

Program new remote control:

First step:

Press the LEARN button on the control board for about 1 second, the indicator LED would turn off, then now means have already enter learning

Second step:

Press any button of the new remote control for about 2 second, then digital display would show the remote number while indicator LED on board starts flash four times with one buzzer sound then now means the learning successfully.

Note! After you press LEARN button, if not receive the new remote signal within 5s, indicator LED would turn on and exit learning.

Remove remote control:

Press and hold the LEARN button for about 5 second, if with one buzzer sound and indicator LED light on, then now means remove remote successfully.

## **Setting of the control board:**

After power on, digital display will self-check from 00-99 with buzzer sound. If indicator LED light on, buzzer stop sound, it means the system is normal.

Basic operation method:

Press and hold the [ FUN] button until the digital display shows P0. Now you enter the menu setting. You could through adjust the [INC+] [DEC-] to increase or decrease the serial number or numerical value. After data adjust well then press [ FUN] to store the data. With one sound of buzzer, the store successfully. After store the data, the digital display would still on the menu number you just set, if you need to enter next menu setting, please press [INC+] or [DEC-] to choose and confirm with [FUN] to enter the menu number you want to set. Such as after you store the P0 value and press [FUN] to store it, then now the digital display would still show the number P0, and if you want go further to adjust P1, please press one [INC+], then digital display show P1, later press [FUN] to enter the P1 setting. And if you not need to enter next menu

setting, you could press [LEARN] button to exit the menu setting.

### 1. To set the soft start time:

When digital display indicates P0, the gate opener is on the soft start time setting. The soft start time adjustable from 0-6s, 0s means close the soft start time, max soft start time 6s. Each time you press and release the [INC+] button, the figure increase by 1; each time you press and release the [DEC-] button, the figure decreases by 1. Press the [FUN] button to store the data when the soft start time chosen, then the soft start time setting finished (Factory set 2s).

### 2. To set the level of stall force:

2a-- When digital display indicates P1, the gate opener is on Motor 1 low speed running stall force adjustment. There are 0-20 levels for optional, each time you press and release the [INC+] button, the figure increase by 1; each time you press and release the [DEC-] button, the figure decreases by 1. Press the [FUN] button to store the data when the stall force level chosen, then the stall force of Motor 1 low speed running stall force adjustment finished. (factory set 6 level)

2b-- When digital display indicates P2, the gate opener is on Motor 1 high speed running stall force adjustment. There are 0-20 levels for optional. Each time you press and release the [INC+] button, the figure increase by 1; each time you press and release the [DEC-] button, the figure decreases by 1. Press the [FUN] button to store the data when the stall force level chosen, then the stall force of Motor 1 high speed running stall force adjustment finished. (factory set 10 level)

2c-- When digital display indicates P3, the gate opener is on Motor 2 low speed running stall force adjustment. There are 0-20 levels for optional. Each time you press and release the [INC+] button, the figure increase by 1; each time you press and release the [DEC-] button, the figure decreases by 1. Press the [FUN] button to store the data when the stall force level chosen, then the stall force of Motor 2 low speed running stall force adjustment finished. (factory set 6 level)

2d-- When digital display indicates P4, the gate opener is on Motor 2 high speed running stall force adjustment. There are 0-20 levels for optional. Each time you press and release the [INC+] button, the figure increase by 1; each time you press and release the [DEC-] button, the figure decreases by 1. Press the [FUN] button to store the data when the stall force level chosen, then the stall force of Motor 2 high speed running stall force adjustment finished. (factory set 10 level)

### 3. To set the high-speed running time:

When digital display indicates P5, the gate opener is on high speed running time setting. There is 0-33s for optional. 0s means without high speed running, gate opener would keep running in slow speed. Max high speed running time 33s. Each time you press and release the [INC+] button, the figure increase by 1; each time you press and release the [DEC-] button, the figure decreases by 1. Press the [FUN] button to store the data when the high-speed running time



chosen, then the high-speed running time setting finished. (factory set 5s)

4. To set the auto close time after swipe card:

When digital display indicates P6, the gate opener is on auto close time setting (NOTE! this auto close time just means the auto close function which realize through external device-). There is 0-99s for optional. 0 means the gate opener would not auto close after swipe card. Max auto close time after swipe card 99s. Each time you press and release the [INC+] button, the figure increase by 1; each time you press and release the [DEC-] button, the figure decreases by 1. Press the [FUN] button to store the data when the auto close time after swipe card chosen, then the auto close time after swipe card finished. (factory set 10s)

5. To set the interval time:

5a. When digital display indicates P7, the gate opener is on open interval time setting. There is 0-10s for optional. 0s means double gates open simultaneously. "1" means the Motor 1 start to open 1 second before Motor 2 start to open. Max open interval time 10s. Each time you press and release the [INC+] button, the figure increase by 1; each time you press and release the [DEC-] button, the figure decreases by 1. Press the [FUN] button to store the data when the open interval time chosen, then the open interval time setting finished. (factory set 0s)

5b. When digital display indicates P8, the gate opener is on close interval time setting. There is 0-10s for optional. 0s mean double gates close simultaneously. "1" means the Motor 2 start to close 1 second before Motor 1 start to close. Max close interval time 10s. Each time you press and release the [INC+] button, the figure increase by 1; each time you press and release the [DEC-] button, the figure decreases by 1. Press the [FUN] button to store the data when the close interval time chosen, then the close interval time setting finished. (factory set 0s)

6. To set auto close time:

When digital display indicates P9, the gate opener is on auto close time setting. There is 0-99s for optional. 0s mean the gate opener would not auto close. Max auto close time is 99s. Each time you press and release the [INC+] button, the figure increase by 1; each time you press and release the [DEC-] button, the figure decreases by 1. Press the [FUN] button to store the data when the auto close time chosen, then the auto close time setting finished. (factory set 0)

7. To set lamp/alarm output control:

When digital display indicates PA, the gate opener is on lamp/alarm output control setting. There is 0-3 for optional. "0" means the alarm on monostability model and the lamp without voltage

output after the gate total close 30s, other time with voltage output. "1" means the alarm on monostability model and the lamp would only flash when gate running. "2" means the alarm on bistability model and the lamp without voltage output after the gate total close 30s, other time with voltage output. "3" means the alarm on bistability model and the lamp would only flash when gate running. Each time you press and release the [INC+] button, the figure increase by 1; each time you press and release the [DEC-] button, the figure decreases by 1. Press the [FUN] button to store the data when the auto close time chosen, then the lamp/alarm output control setting finished. (factory set 0)

#### 8. To set lock time:

When digital display indicate Pb, the gate opener is on lock time control setting. The

lock control time means the time we could control the lock. There is 0-2 for optional. "0" means the lock control time is 1s, "1" means the lock control time is 1.5s, "2" means the lock control time is 2s. Each time you press and release the [INC+] button, the figure increase by 1; each time you press and release the [DEC-] button, the figure decrease by 1. Press the [FUN] button to store the data when the lock control time chosen, then the lock time setting finished. (factory set 0)

#### 9. To choose single/double gate open:

When digital display indicates PC, the gate opener is on single/double gate open setting. There is 0-3 for optional. "0" means the gate could not open by remote, "1" means just can open one single gate, "2" means can just open two leaf gate, "3" means can open one single gate as well as two leaf gates. Each time you press and release the [INC+] button, the figure increase by 1; each time you press and release the [DEC-] button, the figure decreases by 1. Press the [FUN] button to store the data when the single/double gate open chosen, then the remote button setting finished. (factory set 3)

#### 10. To choose photocell work in NC or NO

When digital display indicates Pd, you could choose the photocell work in NO or NC.

Value 00 means work in NO, value 01 means work in NC.

#### 11. To choose single gate or double gate working mode:



When digital display indicate PE, you could choose the gate working mode for double gates or single gate. For only one gate motor, you should choose the value to be 1; For two gates motor, you should choose the value to be 0. ( factory set 0)

#### 12. To reset:

When digital display indicates Po, the gate opener is on rest setting. After enter Po setting, press the [ FUN] to store and then now the reset successfully.